



Built Better To Last Longer

**Light Commercial
Central Heat Recovery Ventilator**

Product Specifications
and

Installation and User Manual

Model

SHRV450RD, SHRV600RD, SHRV1100RD

APPLICATION WARNING

It is always important to assess how the operation of any Heat Recovery Ventilator (HRV) may interact with vented combustion equipment (i.e. gas furnaces, oil furnaces, wood stoves, fireplaces. etc.)

Never install an HRV in a situation where it's normal operation, lack of operation, or partial failure may result in the back drafting on vented combustion equipment such as water heaters, furnaces and fireplaces

**DO NOT ATTEMPT INSTALLING THIS HRV WITHOUT FIRST
READING THIS ENTIRE MANUAL**

Summerraire Mfg.
Peterborough, Ontario,
Canada, K9J 6X6



Table of Contents

Model specifications	2
Air Flow Diagrams	3
Optional Controls.....	4
Installation	8
Weather hood installation.....	10
Dedicated Duct system	12
Integrated HVAC System.....	13
Air Flow Balancing	15
Maintenance.....	18
Maintenance Motors.....	18
Trouble shooting guide	20
Wiring Diagrams	26
Replacement parts list	27

NOTE: Anytime the HRV is powered on allow 20 seconds for the main control to reset prior to making any operational changes.

SHRV 450/600/1100RD MODEL SPECIFICATIONS

SPECIFICATIONS			
DESCRIPTION	SHRV450RD	SHRV600RD	SHRV1100RD
DEPTH	17 3/8"	20 3/8"	32 3/8"
WIDTH	47 7/8"	47 7/8"	47 7/8"
HEIGHT	31"	31 "	31"
VAC @ 60Hz	120	120	120
AMPS	10	10	16
SHIPPING WEIGHT (LBS)	120	180	230
AIR FLOW			
.7" (175 Pa)	250	300	600
.6" (150 Pa)	300	350	700
.5" (125 Pa)	350	400	800
.4" (1100 Pa)	380	470	900
.3" (75 Pa)	420	500	1000
.2" (50 Pa)	460	600	1100
.1" (25 Pa)	480	620	1150
Duct connection "A"	8"	10"	8"
Duct connection "B"	12"	12"	20"

AIR FLOW DIAGRAMS

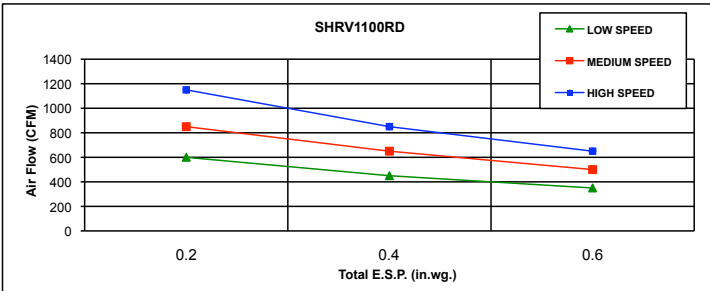
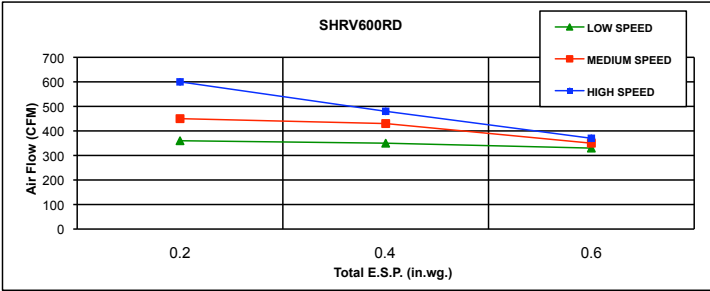
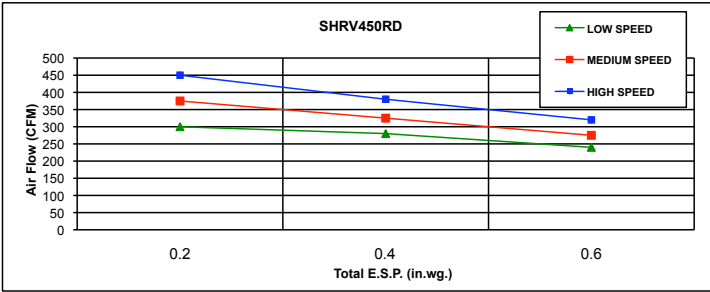

OPTIONAL CONTROLS

20 Minute Remote Timer Touch Pad Model ECPBT

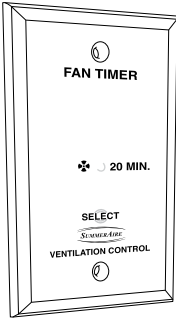

This 20-Minute Touch Pad **MUST** be connected to the “CT” terminals on the HRV exterior. This control will not function if connected to PBT connection points.

Install using 18/2-thermostat wire. Maximum number of ECPBT controls per HRV is eight.

Maximum cumulative lead length is 2000 lineal feet. Touch pads are typically installed where 20 minutes of high speed ventilation may be desired.

Once activated by a momentary push of the SELECT button on the Touch Pad (approximately 3 seconds), the HRV is switched to high speed ventilation and the Touch Pad LED will illuminate. The HRV will reset to the previously selected mode of operation once the 20 minutes have expired. To cancel the selection, depress the SELECT button on the 20-minute Touch Pad for a minimum of 3 seconds. The selection can also be cancelled at any other optional control by momentarily depressing the SELECT button.

NOTE: This control will not respond while a crank timer is operational.

OPTIONAL CONTROLS

Remote Timer Touch Pad Model -PBT

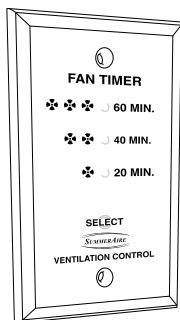

Touch pads are typically installed in any room where 20/40 or 60 minutes of high-speed ventilation may be desired, i.e. bathrooms and/or kitchens. Once activated by a momentary push, these buttons illuminate to indicate high speed activation. If more than one touch pad is installed in the system then all will illuminate upon activation until the timed sequence has expired. The display LEDs on the touch pad will illuminate to represent the time remaining. To cancel a selection simply continue to push the select button until it turns off. Maximum number of touch pads per HRV is eight (8) and 2000 lineal ft of 18/2 thermostat wire.

Wall Mount Dehumidistat Model - SRDEH

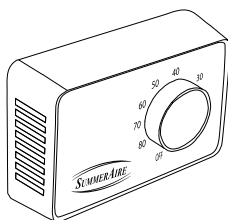

This control is typically installed in an area of the home where humidity may require automatic monitoring. This could be a central location (i.e. near furnace thermostat) or in a specific room (i.e. kitchen, laundry etc.). When wall mount dehumidistats are used, set the HRV internal dehumidistat to OFF. Connect to HRV using 18/2 thermostat wire.

Scout Control

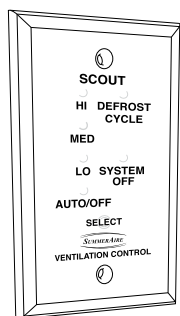

This standard control is detachable from the HRV. Once removed from the HRV, only the power (ON/OFF) remains at the HRV. By positioning the SCOUT remotely to the HRV, you can adjust fans speeds, turn the fan off, select AUTO/OFF, intermittent or turn the main HRV control Off. When the HRV has been turned off using the SCOUT, power still remains on at the HRV ON/OFF switch, however all external controls such as touch pads and dehumidistats will not function. Intermittent- In this mode the ventilation fan will run at low speed for 20 minutes and turn off for 40 minutes. This cycle will continue until cancelled. External devices are active.

The optional Scout installation kit is required for remote mounting. Maximum number of Scout controls per HRV is one (1) with up to 400 lineal ft. of 18/2 thermostat wire.

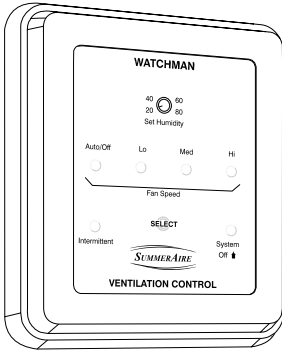

WATCHMAN CONTROL

The WATCHMAN is an optional intermediate remote control. It permits the following function selections;

SYSTEM OFF- In this position all internal and external controls are disabled.

FAN OFF- Ventilation fan is off, cold exhaust port is closed, external devices are active.

FAN SPEED- Low, Medium or HIGH can be selected.

INTERMITTENT- In this mode the ventilation fan will run at low speed for 20 minutes and turn off for 40 minutes. This cycle will continue until cancelled. External devices are active.

AUTO/OFF-In this mode the ventilation fan remains off until activated by either the internal dehumidistat or an external control such as a touch pad or dehumidistat.

RELATIVE HUMIDITY- By rotating the control dial you can select desired levels of indoor humidity. Humidity reduction will only occur during the heating season. Should the set point be below the indoor relative humidity the HRV will automatically switch to high speed. Typically, connection leads would be distributed from a central location and connected at the HRV with a single 18/2 lead. Maximum number of Watchman or Sentinel controls per HRV is four (4) with a total of 1600 lineal ft. of 18/2 thermostat wire.

SENTINEL II CONTROL

The optional Sentinel II control is an external control device providing the user selectable options. These include, Relative Humidity (RH) selection, Auto/Off, Low, Medium and High-speed ventilation, System Off and Intermittent ventilation.

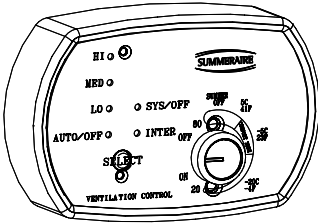

RELATIVE HUMIDITY – By rotating the control dial the indoor RH can be set. In this mode the HRV responds by automatically switching to HIGH-speed ventilation should the indoor humidity be high than the selected level. Humidity reduction only occurs during the heating season.

AUTO/OFF – Ventilation remains off until activated by the internal Sentinel dehumidistat or a remote control device such as a dehumidistat or a timer.

SYSTEM OFF – HRV and external control devices are turned off. Power does remain on at the HRV control.

INTERMITTENT – When selected, 20 minutes of LOW speed ventilation is provided followed by 40 minutes of off time. This cycle repeats until another selection is made. All external devices such as dehumidistat and timers are functional. If a dehumidistat is activated the HRV will switch to High speed ventilation then return to Intermittent when deactivated.

SCOUT / WATCHMAN Indications

MODE	SCOUT	WATCHMAN
Intermittent Fan Off	Auto Off, Blink	Intermittent LED ON, Blink Auto Off
Intermittent Fan Low	Low, Blink	Intermittent LED ON, Blink Low
Filtration	Default fan speed, Slow Blink	Default fan speed, Slow Blink
Summer Switch on Temp <5deg°F	System Off, Blink	System Off, Blink

Note: Up to 2000 lineal ft. of 18/2 thermostat wire may be used in any configuration per HRV with up to eight (8) push button timers. Up to 2000 lineal ft. of 18/2 thermostat wire may be used in any configuration per HRV to service up to four (4) Watchman or Sentinel controls. Up to 400 lineal feet of 18/2 thermostat wire may be used in any configuration per HRV to service up to two (2) Sentinel II controls.

INSTALLATION

Typically the HRV is located in the mechanical room with close proximity to an outside wall. Other installation locations are acceptable provided that the ambient air temperature does not fall below freezing. This is to prevent the condensate drain lines from freezing.

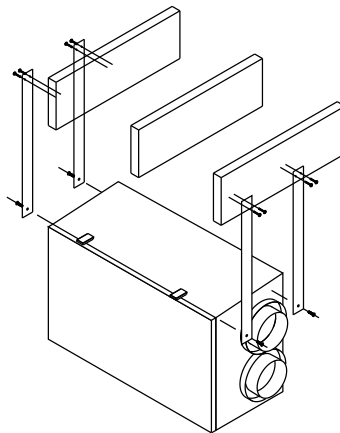

MOUNTING THE HRV

The HRV's may be rotated 180 degrees to permit the connection of the outside air streams to either the left or right hand side. They are factory supplied to be installed with the cold air streams on the right. To install this HRV in the reverse configuration simply remove the plastic drain hole plugs from the top of the cabinet and insert into the drain holes in the bottom. Included with the HRV are four (4) laminated rubber hanging straps. These are to be secured at each of the four corners of the HRV using the screws provided. The other ends of the straps should be secured to the floor joists using large head screws. To ensure proper condensate flow, HRV must be installed level in both directions.

CONDENSATE DRAIN HOSE INSTALLATION

Two (2) drain spigot assemblies are provided. These are to be installed through the drain pan holes provided. Simply install the spigot through the openings and secure in place by installing the nylon washer and nut on the outside of the cabinet. Ensure that the drain holes that are not used are plugged with the drain plugs installed in the cabinet. Once installed, attach 1/2" plastic tubing (not supplied) to the spigots. Create a trap by forming a loop in the tubing. This will prevent the cross contamination of the air streams through the tubing. Ensure that the condensate drain tubing is not exposed to freezing temperatures. Typically the drain line is connected into a floor drain, sink or stand pipe.

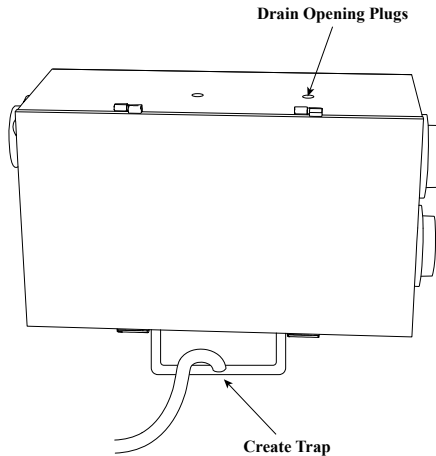

INSTALLATION INSTRUCTIONS

LOCATION

The HRV should be suspended from a supported ceiling ideally in a mechanical room proximate to an outside wall to establish outside venting and weatherhoods. This unit can only be mounted indoors and consideration should be given to the location of available power and water drainage for the unit's condensation. When installing the unit, ensure that it is level and that adequate space is allowed around the unit for easy accessibility into the access doors for service and maintenance.

DUCT SYSTEM

The Duct System must be well designed to allow the HRV to operate at its' maximum efficiency. It is very important the Duct System must be adequately sized and includes no sharp radius bends or tees which will significantly increase the pressure drop in the Duct System and reduce air flows.

Galvanized ducts must be sized for 1200 f.p.m. (6.09 m/s) maximum velocity; this is recommended to avoid excessive pressure drop and noise. Ducting should be as short as possible and use the minimum number of elbows and tees. Connecting duct sections and shorter runs may be flexible ducting one size larger than the metal duct. The use of flexible duct connectors at the HRV will considerably reduce noise transmission. All duct joints must be secured with screws, rivets or duct sealant and sealed with aluminum tape.

DUCTING OUTSIDE OUTSIDE WEATHERHOODS

The Outside Weatherhoods required for operation of the SHRV2500 HRV are to be provided by the installing contractor. Weatherhoods must have built in bird screens to prevent birds and rodents from entering the premise through the ductwork. When designing and locating the fresh air intake, consideration should be given to the best place where the hoods will gather the freshest air, free from restriction.

We recommend:

- No less than 10 ft. (3 m) apart from each other.
- At least 18 in. (46 cm) above ground level or potential snow accumulation.
- Away from sources of contaminants, such as automobile exhaust fumes, gas meters, garbage containers, cooling towers, etc.
- Not exposed to prevailing winds, wherever reasonably possible.

The outside perimeter of the weatherhoods must be caulked to prevent leakage into the building. Roof vents must have adequate curb height for water protection and to be sealed to the ducting.

The design and size of the weatherhoods or louvers chosen by the installer, must allow for adequate free area. Water and snow penetration of the system is minimized when the airflow does not exceed 750 fpm (3.81 m/s) free area velocity.

WEATHERHOOD DUCTING

Galvanized metal ducting with sufficient cross section and with an integral single piece vapor barrier should be used to connect to the HRV to the weatherhoods. All ducting must meet ULC Class 1 Fire Rating and the minimum R-value of the insulation should be equal to 4 (RSI 0.75), or as stated in local codes.

All ducting must be well sealed to prevent air leaks and a sufficient bead of high quality caulking (preferably acoustical sealant) and taping with a high quality aluminum foil tape is recommended to seal the duct to both the HRV and the weatherhoods.

DUCTING WITHIN THE BUILDING

To reduce airflow restriction in the duct system, galvanized ducting should be used from the HRV to different areas within the building whenever possible. Also, to minimize airflow losses in the duct work system, all ducts should be as short as possible and incorporate as few elbows as possible. The use of 45 ° elbows is preferred to 90 ° elbows and Y tees instead of 90 ° tees is also recommended.

All duct joints must be fastened securely and wrapped with a quality duct tape, such as aluminum foil tape, to prevent leakage.

NOTE: See Installation Warning under the “Integrated HVAC System “ section.

STALE AIR (RETURN) DUCT SYSTEM

The Stale Air (Return) Duct System is used to draw stale air from the points of the building where the worst air quality problems occur. Balancing dampers and, or, adjustable grilles are recommended on all return air lines which are used (during installation) to help balance the “ draw “ from different areas of the building. Note that the installation schematics show balancing dampers and, or, adjustable grilles on all return air lines coming back to the HRV. Please refer to figs. 1-3 to view the various installation system options.

A balancing damper is required prior to the HRV to balance the stale air exhausted with the fresh air supply entering the building.

Return air extraction points should be located at the opposite side of the room to the fresh air inlet. The inlets may be located in the ceiling or high on the walls and fitted with inlet grilles.

Many commercial activities produce air contaminants in the form of dusts, fumes, vapors and gases. Contaminates should be controlled at the source so that they are not dispersed through the building nor allowed to increase to toxic concentration levels. The HRV allows for economical operation of the HVAC system, while effectively removing contaminants from the space. In designing the exhaust portion of the system, the exhaust grilles are placed so as to remove the contaminants while not allowing them to enter the breathing zone of the occupants.

For contaminants that are lighter than air, grilles should be located high on the wall. If contaminants are heavier than air a lower placement of the grilles will be required. Information on contaminants specific gravity and toxicity should be available from the chemical data sheets.

Dedicated Duct System

In this arrangement the HRV is installed with a dedicated duct system. All applicable rooms are exhausted and provided with fresh air supply as required. The main advantage of this type of installation is it provides the ability to balance the exhaust and supply air streams for each serviced room. The HRV system can also be operated independently of the forced air heating/cooling system. Please refer to fig. below.

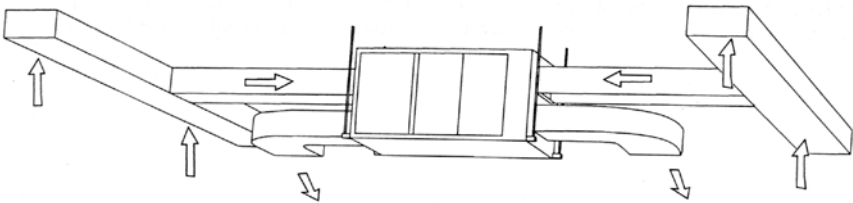

SUPPLY AIR DUCT SYSTEM

The fresh air supply ductwork from the HRV may be directly connected to the return air duct of the forced air system. When directly connected, it is recommended that the air handler blower be in constant operation to move the fresh air about the building (see warning under “The Integrated HVAC System”). Also, it is advisable to include a short length fabric flex duct or other non – metallic

connector in this hard duct line in order to keep the HRV acoustically isolated and separately grounded (electrically) from the air handler. This will avoid a possible shock hazard to service people if a short to ground develops in one of the devices. It may be necessary to install a separate fresh air supply ductwork system if the heating is other than forced air.

When installing an HRV, the designer and installer should be aware of local codes that may require smoke detectors and / or firestops in the HVAC or HRV ductwork. Because an HRV is designed to bring fresh air into the building, structures may require a supply voltage interrupt when fire or smoke or flame sensors are triggered or central fire system is activated.

Supply air grilles may be ceiling or high wall mounted. Avoid incoming fresh air grilles that could cause a direct draft on the occupants as the incoming air may be below room temperature. A reheat duct heater can be installed to improve occupant comfort. Information on electric or hydronic duct heaters is commercially available.

INSTALLATION TIPS

1. Whichever method is chosen to operate the SHRV600RD, keep in mind that Air – to – Air exchangers are not “ booster fans “, and are not normally sized to ventilate at a steady rate.
To achieve optimum performance from the SHRV600RD, the desired ventilation rate (speed of the system) should be reached before the contaminant has reached its’ maximum.
2. It is recommended that backdraft dampers be installed in the supply and exhaust ductwork to the outside, to prevent air from entering in through the HRV when the HRV is OFF. Failure to install backdraft dampers may result in damage to HVAC equipment and / or other building components.

INTEGRATED HVAC SYSTEM

Increasingly, the HRV has become an integral component of the commercial HVAC system. HRV’s are very versatile, being able to provide fresh air directly to the return air plenum of a rooftop heat / cool unit or into a ceiling return air plenum or directly into the ceiling space near the air handlers intake. Special care and attention should be given if connecting this unit to any air handler or other unit that may draw more than the SHRV600RD is designed to accommodate.

Installations where it is satisfactory to provide general exhaust from the space, the air to be exhausted may be taken directly from the return air plenum to the HRV as it is drawn back to the air handler. Fresh air supplied by the HRV is then introduced directly into the return air plenum but at a location closer to the air handler. The air handler would have a constant running blower to effectively

distribute the fresh air and remove the stale air. Balancing dampers would be located in both the HRV supply and exhaust ducts between the return air plenum and the HRV.

ELECTRICAL

An external disconnect must be installed prior to the HRV. This disconnect shall be turned off and locked out before servicing the unit. All electrical connections shall be made by a qualified, and where required by law, a licensed electrician.

Interior Ducting

Ducting to the central forced air ductwork system, or if used, a dedicated duct system, should be made of galvanized metal whenever possible.

To minimize airflow losses, runs should be kept as short as possible using 45 degree elbows instead of 90 degree. Whenever possible use “Y” fittings instead of “T” fittings.

All joints must be fastened with screws, rivets or duct sealant and wrapped with a quality duct tape to prevent leakage. If standard grills are used, it is recommended that wall grills of not less than 6” x 12” and floor grills of no less than 4” x 10” be used to minimize air flow restrictions.

Fresh Air Supply Ducting

Fresh air supply grills may be either wall or ceiling mounted. Avoid locating these grills where room occupants may be exposed to the fresh air supply as this air temperature may be slightly less than the room air temperature.

Stale Air Return System

The stale air return system is used to extract humid, stale air from the areas of the dwelling where the worst air quality conditions might exist.

Note: Check local code compliance before implementing.

Air Flow Balancing

READ THE APPLICATION WARNING AT THE FRONT OF THIS MANUAL.

A magnehelic gauge and pilot tube flow measuring system is used for easy and accurate air flow measurement

Upon completion of the installation it is necessary that the Ventilation System be balanced. This is necessary to ensure that the volume of air being exhausted from the dwelling is equal to the volume of air being supplied. Balancing will also ensure that the HRV is operating at it's maximum efficiency.

Detailed check list to be carried out prior to balancing.

- a) Install air flow station in each of the warm air streams.
- b) Ensure that all ductwork is secured and sealed.
- c) Drain connections are in place and drain trap filled with water.
- d) Dwelling vapour barrier is complete and intact.
- e) Fireplace dampers, windows and doors are closed.
- f) Clothes dryer off, (if vented to the outdoors)
- g) Furnace, hot water heater, (non direct vent) are turned off.
- h) All other exhaust fans are off.
- i) Ensure that HRV filters and core are in place and integral balancing dampers are wide open.
- j) Power up HRV and set to high speed.
- k) Adjust all branch tech grills and registers to desired air flows.
- l) After taking readings at both the stale air being exhausted and the fresh air supply air stream, damper down the higher air flow stream with the integral balancing damper to equal the lower volume air stream.
- m) Once the air flows are balanced lock the balancing dampers in place.
- n) While it is necessary to ensure that both air streams are balanced within 10% of each other, a near balanced condition should be possible.
- o) Upon completion, return the fan speed selection to the normal speed of low.

A positive pressure situation within the interior may drive moist air into the external walls of the dwelling where, in cold weather, it may condensate, potentially causing structural damage.

A negative pressure within the interior may have severe undesirable effects. In some geographic locations, radon gas may be drawn into the interior space. A negative condition may also cause back drafting of vented combustion appliances such as fireplaces and furnaces.

When it is possible for excessive pressurization or depressurization of a dwelling to occur it may be necessary to perform a Pressure Test. This test is most important where fuel fired devices are installed that are susceptible to spillage.

IT IS YOUR RESPONSIBILITY TO DETERMINE IF THE “PRESSURE TEST” IS REQUIRED..

Summaire HRV Air Flow Balancing

It is necessary to have balanced air flows in any HRV. The volume of air brought in from outside must be equal to the volume of air exhausted by the HRV. If the air flows are not properly balanced :

- The HRV may not operate at its' maximum efficiency.
- A negative or positive air pressure may occur in the building.
- The HRV may not defrost properly.
- Failure to balance the HRV may void warranty

Excessive positive pressure may drive moist indoor air into external walls of the building where it may condense (in cold weather) and degrade structural components. It may also cause key holes to freeze up.

Excessive negative pressure may have several undesirable effects. In some geographic locations, soil gases, such as methane and Radon gas may be drawn into the building through basement / ground contact areas. Excessive negative pressure may also cause back drafting of atmospherically vented combustion appliances.

**Read the Application WARNING on the Front Page of This Manual.
Prior to balancing, insure that:**

1. All sealing of the ductwork system has been completed.
2. All of the HRV's components are in place and function properly.
3. Balancing dampers are open.
4. HRV is on High Speed.
5. Air flows in branch lines to specific areas of the building should be adjusted first, prior balancing the HRV. A smoke pencil used at the grilles is a good indicator of each branch line's relative air flow.
6. After taking readings of both the stale air to the HRV duct and fresh air to the building duct the lower CFM (L/s) velocity reading should be left alone, while the duct with the higher reading should be dampered to match the lower reading.
7. Return HRV to appropriate fan speed for normal operation.

Preliminary Procedures:

1. Seal all the unit's ductwork with foil tape.
2. Close all windows and doors and fireplace damper, turn off all exhaust devices (range hoods, clothes dryer, bath fan, etc.), make sure all filters are clean.
3. Set build-in balancing dampers fully open. Tap 1/8" hole in ductwork for pitot tube insertion.

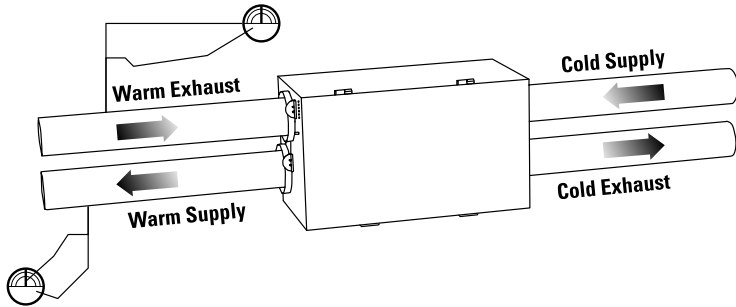

Balancing Procedures:

1. Set HRV to high speed. Make sure that the furnace blower is ON if the installation is in any way connected to the ductwork of the furnace. If not, leave the furnace blower OFF. Adjust air flow in branch lines if using source point exhaust and/or supply.
2. If outside temperature is below -3°C (26°F), make sure defrost light is not on while balancing.
3. Place magnahelic gauge on a level surface and adjust it to zero. Insert pitot tube into exhaust air ductwork with tip aligned with ductwork, pointing away from HRV, into air flow. Record the reading on gauge.
4. Move kit to other air stream HRV, insert pilot tube into fresh air ductwork with tip aligned with ductwork, pointing towards HRV, into air flow. Record reading on gauge. Adjust fresh air balancing damper until reading is approximately the same as in exhaust air ductwork. If the reading in the fresh air ductwork is less than in the exhaust air, go back and adjust the exhaust balancing damper to equal the fresh air flow.
5. Secure dampers in place with fastening screw. Duct tape over pitot tube holes. Convert FPM reading on gauge to CFM with conversion chart and record on balancing sticker and affix to HRV near label.
6. Note: Unit is considered balanced if readings are within $\pm 10\%$.

MAINTENANCE

As with any mechanical system, a dedicated maintenance program will prolong the life of the equipment, and maintain its' optimum performance. We recommend at least two (2) full inspections and cleanings per year under normal operating conditions, and more, if circumstances warrant it.

Service Should Include:

- Cleaning of screens protecting the outside hoods
- Cleaning the core – core assembly is made up of 3 cores. To access the core, remove service panels and slide core half way out. Wash core(s) protruding from the cabinet with water and / or a mild cleaning solution. Push core through to the other side of the cabinet and repeat the procedure to clean the other side of the core. In many cases, only a vacuuming of the core surface is required.
- Always ensure that cores are installed correctly. Refer to labels referring to “Core This Way Up” and “Air Filters This Side”.
- Inspect filters and replace as necessary.
- Wipe down drain pans and inside of the cabinet using a mild disinfectant.
- Ensure condensate drain has free flow of moisture.
- Inspect blowers and electrical disconnect panel.
- Confirm operation.

MOTORS

Apply 4 – 5 drops of oil to the ports at each end of the motor every 12 months is required. We strongly recommend that the motor (s) should be oiled once every year in order to extend its' life. USE S.A.E. 20W NON – DETERGENT OIL. Do not “ over oil “, as this may damage the motor. Depending on the HRV specifications, the motors may have sealed bearings that do not require oiling. An inspection of the motors will identify if oiling is required.

HRV TROUBLE SHOOTING GUIDE OPERATION GUIDE

PROBLEM	PROBABLE CAUSE	SOLUTION
PERSISTENT CONDENSATION ON WINDOWS	IMPROPER ADJUSTMENT OF DEHUMIDISTAT(S). IMPROPER VENTILATION RATE.	ADJUST DEHUMIDISTAT(S) TO CORRECT RH READING (see operation manual), ADJUST TO A LOWER SETTING. CHECK OPERATION OF DEHUMIDISTAT. IF DEFECTIVE, REPLACE. INSTALL A DEHUMIDISTAT IN LIVING AREA OF HOME. ENSURE HRV IS ON CONTINUOUSLY. INCREASE FAN SPEED. BALANCE SYSTEM.
DEFROST NOT WORKING.	BROKEN DAMPER BLADE ASSY.	REPLACE.
FRESH AIR DUCT FROZEN OR VERY COLD (DEFROST LIGHT COMES ON).	FAILED MAIN CONTROL BOARD. DEFECTIVE DAMPER MOTOR.	IF DAMPER DOOR DOES NOT OPERATE DURING "START UP SELF DIAGNOSTIC" BUT POWER LIGHTS ARE ON, BOARD MAY REQUIRE REPLACEMENT. REPLACE. INSPECT CONNECTION BETWEEN MOTOR SHAFT AND DAMPER, COUPLING MAY BE LOOSE.
HUMIDITY LEVEL TOO LOW	HRV AIR FLOWS IMPROPERLY BALANCED. DEHUMIDISTAT CONTROL SET TO LOW. LIFE STYLE OF OCCUPANTS. VENTILATION RATE TOO HIGH	BALANCE HRV SET DEHUMIDISTAT TO A HIGHER SET POINT. HUMIDITY MAY HAVE TO BE ARTIFICIALLY ADDED, i.e. HUMIDIFIER. ADJUST TO LOWER FAN SPEED OR INTERMITTENT
HUMIDITY LEVEL TOO HIGH	HRV AIR FLOWS IMPROPERLY BALANCED HRV UNDERSIZED.	BALANCE HRV

PROBLEM	PROBABLE CAUSE	SOLUTION
	DEHUMIDISTAT SET TOO HIGH	SET DEHUMIDISTAT TO A LOWER SETTING.
	HRV UNDERSIZED TO HANDLE HOT TUB, INDOOR POOLS, ETC.	COVER POOLS, HOT TUBS ETC. WHEN NOT IN USE.
	LIFESTYLES OF OCCUPANTS	AVOID HANGING CLOTHES TO DRY INSIDE. AVOID STORING WOOD INSIDE AND VENT DRYERS OUTSIDE.
HRV AND/OR DUCTS FROSTING UP	HRV AIR FLOW IMPROPERLY BALANCED	BALANCE HRV NOTE: FROST BUILD UP IS EXPECTED ON CORES PRIOR TO INITIATING A DEFROST CYCLE.
SUPPLY AIR FEELS COOL	HRV AIR FLOWS IMPROPERLY BALANCED.	BALANCE HRV.
	POOR LOCATION OF SUPPLY GRILLS.	LOCATE GRILLS HIGH ON WALLS OR UNDER BASEBOARDS.
	OUTDOOR TEMPERATURE EXTREMELY COLD.	IF SUPPLY AIR IS INSTALLED INTO RETURN AIR OF FURNACE, FURNACE FAN NEEDS TO RUN CONSTANTLY TO DISTRIBUTE VENTILATION AIR COMFORTABLY. ENSURE THAT A BREATHER "T" IS INSTALLED IN SUPPLY DUCT. PREHEATER MAY BE REQUIRED.
WATER IN BOTTOM OF HRV	DRAIN PAN (S) PLUGGED	ENSURE "O" RINGS ON DRAIN SPIGOT SEATS PROPERLY LOOK FOR KINKS IN LINE.
	DRAIN LINES OBSTRUCTED	CHECK WATER DRAIN CONNECTIONS. MAKE SURE WATER DRAINS PROPERLY FROM THE PAN(S)
	HRV HEAT EXCHANGE CORE NOT INSTALLED PROPERLY	CHECK ORIENTATION LABEL ON FRONT OF CORE AND POSITION CORE CORRECTLY. HRV MAY NOT BE LEVEL
AIR FLOWS ARE POOR	HRV AIR FLOW IMPROPERLY BALANCED	BALANCE HRV.
	FILTER/CORE PLUGGED UP	CLEAN AND REINSTALL
	1/4" MESH ON OUTSIDE HOODS PLUGGED IMPROPERLY SIZED DUCTING	REMOVE OBSTRUCTIONS IN DUCT(S), HOODS AND GRILLS.

PROBLEM	PROBABLE CAUSE	SOLUTION
	UNDER SIZED HRV MALFUNCTION WITH HRV	INSPECT FAN WHEELS TO ENSURE THEY ARE TURNING FREELY
CONDENSATION OR ICE BUILD UP IN INSULATED DUCT	INCOMPLETE VAPOUR BARRIER AROUND INSULATED DUCT UNUSUALLY HUMID AMBIENT DOOR GASKET DAMAGED	TAPE ALL JOINTS ENSURE THAT VAPOUR BARRIER IS COMPLETELY SEALED WRONG APPLICATION OF HRV REPLACE GASKETING
WATER LEAKS	HRV NOT LEVEL EXCESSIVE WATER DUE TO NEW WET CONSTRUCTION	LEVEL HRV OPERATE HRV ON LOWER SPEED ie. INTERMITTENT
FROST ON FRESH AIR INTAKE & STALE AIR EXHAUST FLEX	HRV CORE INSTALLED IN REVERSE VAPOUR BARRIER INCOMPLETE	INSTALL CORE CORRECTLY "FRONT" OF CORE HAS INSTALLATION INSTRUCTION LABEL INSTALL WITH LABEL FACING HRV DOOR REPAIR SEAL OF ALL CRACKS AND TEARS
HRV STATUS PANEL FLASHING HIGH CONTINUOUSLY	HRV INTERNAL DEHUMIDISTAT SET TO LOW	ADJUST DEHUMIDISTAT TO HIGHER SET POINT

CONTROL FUNCTION

NOTE: ALL EXTERNAL MAINTENANCE TO BE PERFORMED BY A CERTIFIED ELECTRICIAN ONLY

PROBLEM	PROBABLE CAUSE	SOLUTION
NO POWER INDICATION AT ON/OFF SWITCH	LACK OF POWER AT SUPPLY	CHECK FOR POWER
	DOOR SAFETY SWITCH NOT ENGAGED DEFECTIVE DOOR SWITCH	ENSURE THAT DOOR SWITCH IS OPERATING REMOVE MAIN ACCESS DOOR AND CONTROL COVER PLATE. APPLY POWER TO HRV AND CLOSE DOOR SWITCH AND TEST THE TWO LEADS ON BACK OF SWITCH, ONE SHOULD HAVE A READING. CLOSE DOOR SWITCH AND CHECK OTHER LEAD WITH METER AND KNOWN NEUTRAL. IF NO READING IS PRESENT THEN REPLACE SWITCH.
	DEFECTIVE POWER SWITCH	POWER UP HRV, CLOSE DOOR SAFETY SWITCH, TURN POWER SWITCH TO ON. PLACE ONE LEAD OF VOLT METER ON KNOWN NEUTRAL AND THE OTHER ON TERMINALS ON BACK OF SWITCH, ONE AT A TIME. VOLTAGE READING SHOULD BE LINE VOLTAGE ON BOTH BLACK LEADS. IF NOT, THEN REPLACE SWITCH. CONFIRM NEUTRAL AT SWITCH LEAD WITH KNOWN NEUTRAL. DISCONNECT POWER TO HRV. IDENTIFY KNOWN NEUTRAL, POSITION ONE LEAD OF OHM METER ON KNOWN NEUTRAL AND OTHER AT NEUTRAL LEAD AT REAR OF SWITCH. IF NO READING THEN INVESTIGATE CONNECTION OF NEUTRAL LEAD WIRE. AND OUTPUT. IF NO READING THEN REPLACE FILTER.
NOTHING WORKS	POWER OFF – UNPLUGGED FROM POWER SOURCE	RESTART HRV. THIS WILL RESET THE ELECTRONIC CONTROL BOARD

NOTE: ALL EXTERNAL MAINTENANCE TO BE PERFORMED BY A CERTIFIED ELECTRICIAN ONLY

PROBLEM	PROBABLE CAUSE	SOLUTION
DAMPER MOTOR NOT ACTUATING, NO ACTION WHEN SHORTING DEHUMIDISTAT TERMINALS	CHECK ELECTRICAL PANEL - CIRCUIT BREAKER – FUSE. CHECK HRV DOOR INTERLOCK SWITCH	RESET CIRCUIT BREAKER OR REPLACE FUSE, OR YOU MAY BE REQUIRED TO CALL AN CERTIFIED ELECTRICIAN. REPLACE DOOR SWITCH.
BLOWER MOTOR NOT OPERATING BUT POWER LIGHT ON.		UNPLUG 120V POWER SOURCE, APPLY 120V DIRECTLY TO MOTOR. IF MOTOR DOES NOT RUN, REPLACE CAPACITOR, IF MOTOR DOES NOT RUN, REPLACE MOTOR.
DEHUMIDISTAT (S) NOT WORKING (INTERNAL AND/OR REMOTE WALL MOUNTED)		DISCONNECT LEADS AT DEHUMIDISTAT AND SHORT TOGETHER. IF HRV RESPONDS TO HIGH SPEED THEN REPLACE DEHUMIDISTAT.
HRV MAKES AN ANNOYING NOISE	SUPPLY OR EXHAUST BLOWER WHEEL OUT OF ADJUSTMENT	REMOTE MOTOR ASSEMBLY AND TIGHTEN SCREW ON MOTOR SHAFT. CHECK SUPPLY /EXHAUST WHEELS FOR BALANCE. REPLACE IF NECESSARY. ENSURE THAT FAN WHEELS ARE NOT RUBBING ON FAN HOUSING INLET RING.
NOISE LEVEL TOO HIGH AT DISTRIBUTION REGISTERS WHEN HRV ON HIGH SPEED	AIR DUCT SYSTEM TOO SHORT	REDESIGN DUCT SYSTEM OR INSTALL SILENCER.
TOUCH PAD	CHECK FOR CORRECT WIRE GAUGE (18) OR WIRING TO HRV OR SWITCH IMPROPER CONNECTION TO 24V TERMINALS	CONFIRM WIRING TO WIRING DIAGRAM. CHANGE TO CORRECT WIRE GAUGE. CHECK TOUCH PAD FOR PROPER CONNECTIONS. ENSURE THAT CORRECT SWITCHES ARE BEING USED.

NOTE: ALL EXTERNAL MAINTENANCE TO BE PERFORMED BY A CERTIFIED ELECTRICIAN ONLY

PROBLEM	PROBABLE CAUSE	SOLUTION
DAMPER MOTOR STAYS IN DEFROST. DEFROST L.E.D NOT ILLUMINATED. LEAD.	EXTERNAL LOW VOLTAGE WIRE IS SHORTED OUT BY A STAPLE OR NAIL	DISCONNECT LEADS AT BOTH ENDS @ TEST FOR CONTINUITY BETWEEN LEADS.
DAMPER MOTOR STAYS IN DEFROST. DEFROST L.E.D NOT ILLUMINATED. LEAD.	DEFECTIVE DAMPER MOTOR DEFECTIVE CONTROL BOARD	PICK COMMON COLOURED (2) DAMPER MOTOR LEADS. PROBE 1 OF THESE LEADS WITH 1 LEAD FROM METER. WITH THE OTHER METER LEAD PROBE 1 OF THE OTHER SINGLE METER SHOULD READ 30V OR 27V. THE POSITION OF THE DAMPER MOTOR DETERMINES THE VOLTAGE YOU WILL READ (IT WILL BE ONE OR THE OTHER) IF THESE READINGS ARE OBTAINED, CHANGE THE DAMPER MOTOR. IF NO VOLTAGE PRESENT, OR VOLTAGES ARE THE SAME, CHANGE THE CONTROL BOARD.
FAN SPEED DOESN'T SEEM TO CHANGE AS SELECTIONS ARE MADE ON SELECT BUTTON.	IMPROPER DUCT SYSTEM INSTALLED.	ENSURE THAT MOTOR AMP DRAW DOES NOT EXCEED NAMEPLATE RATING. INCREASED STATIC (I.E. DAMPERING) MAY BE NECESSARY.
	INCORRECT VOLTAGE; MEASURE LINE VOLTAGE & VOLTAGE TO MOTOR.	DETERMINE IF IT'S CORRECT AND CONFIRM THAT VOLT METER IS READING CORRECTLY. ALL VOLTAGES MUST BE MEASURED WITH DUCT SYSTEM INSTALLED. LOW SPEED 97 VOLTS MEDIUM SPEED 105 VOLTS HIGH SPEED 120 VOLTS IF THE VOLTAGES ARE CORRECT THEN THE DUCT SYSTEM STATIC IS TOO LOW.
CONTROL BOARD CHANGED UNIT DOES NOT SEEM TO RUN PROPERTY	DIP SWITCHES NOT SET AS INSTRUCTED	RESET DIP SWITCHES TO ORIGINAL SPECIFICATIONS.

NOTE: ALL EXTERNAL MAINTENANCE TO BE PERFORMED BY A CERTIFIED ELECTRICIAN ONLY

PROBLEM	PROBABLE CAUSE	SOLUTION
WHEN UNIT IS INITIALLY POWERED ON, UNIT STAYS IN DEFROST MODE LONGER THAN 10 MINUTES	DEFECTIVE MAIN CONTROL BOARD	CHANGE BOARD. WHEN CHANGING BOARD ALWAYS SET DIP SWITCHES TO EXACT POSITION OF DEFECTIVE BOARD BEING REPLACED.
DEFROST CYCLE ACTIVE DURING ABOVE FREEZING OUTDOOR TEMPERATURE	DEFECTIVE TEMPERATURE SENSOR	CHANGE SENSOR
LATCH OPENS	EXCESSIVE CLOSING FORCE REPEATED FORCING OF LATCH WEARS OFF LOCKING TAB ALLOWING IT TO POP OPEN. FORCING DOOR SHUT, THEN FORCING LATCH WEARS OFF LOCKING TAB ON LATCH.	REPLACE LATCH LATCH MUST BE OPEN PRIOR TO LATCHING DO NOT PULL DOOR SHUT
LOCKED ON HIGH SPEED	DEHUMIDISTAT SET TOO LOW DEHUMIDISTAT DEFECTIVE	REDUCE SET POINT REPLACE
NOT ALL WALL SWITCH CONTROL ILLUMINATE WHEN ONE IS ACTIVATED	DEFECTIVE CONTROL. FEED LINE TO WALL SWITCH CONTROL TOO LONG	REPLACE SHOULD BE LESS THAN 2,000 LINEAL FEET IN TOTAL

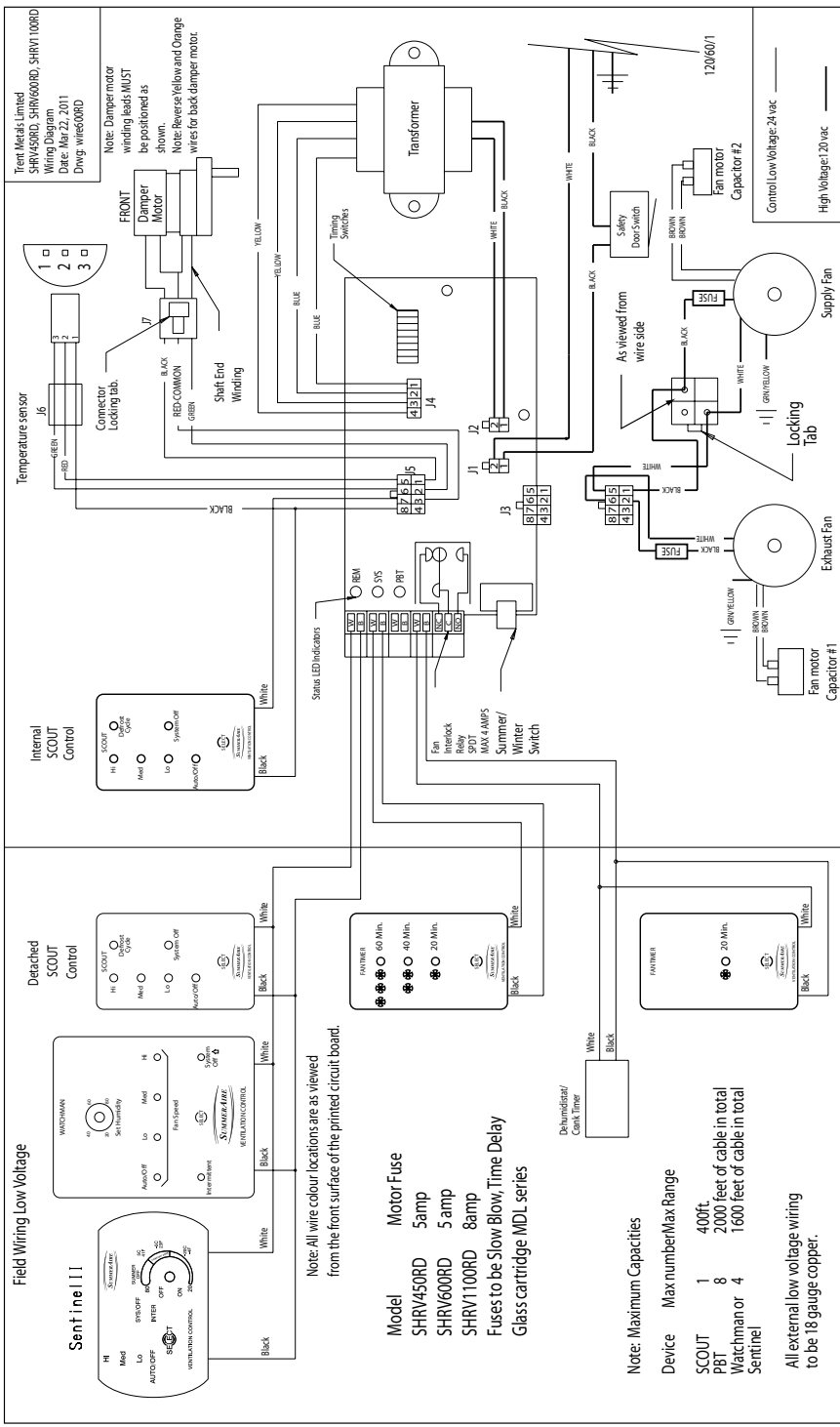

Replacement Parts List

Part Number	Description	450RD	600RD	1100RD
8.CAP370V5MF	5 MF capacitor	X	X	
2.CAP15UF	15 UF capacitor			X
8.BOARDCOMMRD	REV. 6.50 BOARD	X	X	X
8.BOARDSCOUT	Scout/ Dcon Board	X	X	X
8.CORE450RD	Coroplast 450RD 21X21X15	X		X
8.CORE600RD	Coroplast 600RD 21X21X18		X	
8.FILT15202	15X20X2 Filter 2/pkg	X		X
8.FILT18202	18X20X2 Filter 2/pkg		X	
8.FUSE5A	5 Amp Fuse 2/pkg	X	X	
8.FUSE8A	8 Amp Fuse 2/pkg			X
8.FUSEHLDR	Fuse Holder	X	X	X
1.HGDR1	Door Hinge #96-10-310-11	X	X	X
8.HGDR3	Knuckle Hinge #96-10-320-11	X	X	X
8.HSG1343734	Housing #1343 7 3/4 c/w rings 2/pkg	X		
8.HSG1343912	Housing #1343 9 1/2 c/w rings 2/pkg		X	X
8.LATCH300	Door Latch 300 serieies	X	X	X
8.MTR11863COMRD	Emerson Motor #11863, motor mount 92A855	X	X	
	1/4HP 115V 1075RPM 3SP, c/w cap			
8.MTR1694	Emerson Motor #1694 motor mount 92A855			X
	1/2HP 115V 1625 RPM, 3SP			
8.MTRDMPR24VR	Damper Motor 24V Reversing	X	X	X
8.STRAP36	hanger Strap 36" 4/pkg	X	X	X
8.SWPADDLE	Micro Switch 3/4HP 125V 15 Amps	X	X	X
8.TRANS1	Transformer AH76 20VA sec2x12v class 2	X	X	X
8.WHEEL450RD	Wheel C800-600HD CCW 1/2" Bore	X		
8.WHEEL600RD	Wheel C800-800HD CCW 1/2" Bore		X	X



Built Better To Last Longer

Summerraire Mfg.
Peterborough, Ontario
Canada, K9J 6X6

X-COMMRD-INSMAN-EN-REV10
June 16, 2011

Specifications and illustrations subject to change
without notice and without incurring obligations.