



Built Better to Last Longer

HEAT RECOVERY VENTILATORS

INSTALLATION AND OWNERS OPERATING MANUAL

MODEL SHR2500DD

APPLICATION WARNING !!

CAUTION

Before installation, consideration must be given to how this system will operate if connected to any other piece of mechanical equipment, i.e. a forced air furnace or air handler, operating at a higher static. After installation, the compatibility of the two pieces of equipment must be confirmed by measuring the airflow's of the Heat Recovery Ventilator (HRV) using the balancing procedure found in this manual.

It is always important to assess how the operation of any Heat Recovery Ventilator may interact with vented combustion equipment.

NEVER install a Heat Recovery Ventilator in a situation where its' normal operation (including defrost function), lack of operation or partial failure may result in the back drafting or improper functioning of vented combustion equipment!

**DO NOT ATTEMPT INSTALLING UNIT
WITHOUT FIRST READING THIS ENTIRE MANUAL**



**Summerraire Mfg.,
Peterborough, Ontario,
Canada, K9J 6X6**

TABLE OF CONTENTS

PRODUCT SPECIFICATIONS.....	3
INTRODUCTION	7
HRV SIZING CHART	8
INSTALLATION INSTRUCTIONS	9
INSTALLATION METHODS.....	12 & 13
PITOT TUBE AIR FLOW BALANCING	15
GENERAL OPERATING.....	18
GENERAL MAINTENANCE.....	20
WIRING DIAGRAM.....	21
PARTS LIST	22 & 23
TROUBLE SHOOTING GUIDE	24
WARRANTY	25

PRODUCT SPECIFICATIONS

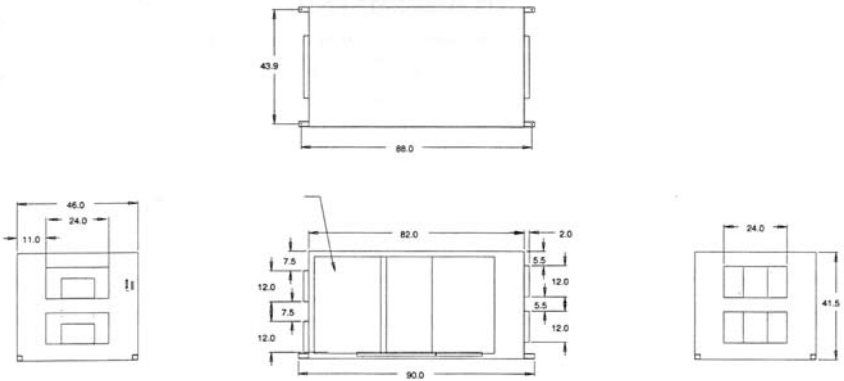

NOMENCLATURE

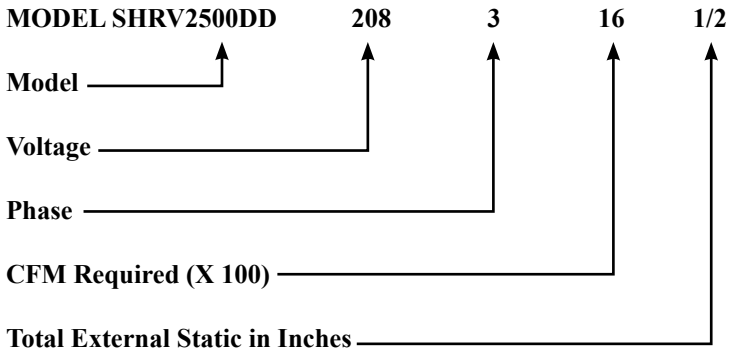

MODELS AVAILABLE:

230/1/60 single speed 1 H.P.

208/230/460/575 3 phase single speed 1 H.P. and 2 H.P.

Refer to Model selection table for capacities available.

MOTORS: Type ODP motors with sleeve bearings or fan cooled with ball bearings depending on application. Available in 1hp or 2hp in various voltages and phases including 208/230/460/575 3 phase and 230/1 phase..

CABINET: Cabinet is white powder coated 18ga. Galvanized with 2” foil faced reinforced insulation. Includes six (6) Access Doors to service air filters, drain pans, heat recovery cores and fan and motor assemblies.

HEAT RECOVERY CORE: Three (3) polypropylene cores located for easy removal for cleaning.

BLOWERS: Belt Drive, double inlet, forward curved centrifugal blowers. Painted housing and galvanized wheels.

FILTERS: Four (4) - 16 “ X 20 “ X 4 “ Pleated Disposable Air Filters

DEFROST: Damper defrost system is actuated when supply air temperature entering HRV falls below preset temperature. This causes cold supply air to be dampened off thereby passing ambient indoor air from the building over the core for a 5-7 minute cycle until the core defrosts.

CONTROLS: Power On/Off is field supplied as a fused disconnect. Control keypad on the unit gives several options including; Hi420 20 minutes of run time on high speed, Intermittent ventilation repeating cycle of 20 minutes of fan on followed by 40 minutes of fan off, Auto Off to put the unit into standby off mode until activated to high speed ventilation by a remote device or a Remote Push Button or Crank Timer. Standby mode, power to the main control remains on but the Remote Devices are inactive, cold supply damper closes.

OPTIONAL REMOTE CONTROLS: Remote On/Off toggle switch, Crank timers, Remote 20 minute Push Buttons (Maximum 6) and Dehumidistats.

CONDENSATION: Unit supplied with Drain Spigots and a Tee fitting. Drain hose (5/8 inside diameter) to be field supplied.

MOUNTING: Indoor application only, fasten at four corners of unit using field supplied threaded rod for ceiling suspension

SHIPPING WEIGHT: 750 pounds

NOTE: ALL WIRING MUST BE IN COMPLIANCE WITH ALL NATIONAL – STATE – PROVINCIAL AND LOCAL CODES

SHRV2500DD
AIR FLOW RATE (CFM)

NOTE: DRIVE SELECTIONS SHOWN ARE BASED ON 56 (56H) FRAME MOTORS
T= TOP FAN ASSY B= BOTTOM FAN ASSY.
ALL PULLEYS MUST BE CAST IRON

FAN	MOTOR	CFM @ STATIC	MOTOR PULLEY (Inches)	TURNS OPEN	BLOWER PULLEY	BUSHING (Browning) (Inches)	BELT (Inches)
T	1 HP	1200 @ .25"	3.15 x 5/8	2.0	8.75	HX1	B49
B	1 HP	1200 @ .25"	3.15 x 5/8	3.0	8.75	HX1	B48
T	1 HP	1200 @ .50"	3.15 x 5/8	3.0	6.75	HX1	B45
B	1 HP	1200 @ .50"	3.15 x 5/8	4.0	6.75	HX1	B44
T	1HP	1200 @ .75"	3.15 x 5/8	3.5	5.75	HX1	B43
B	1 HP	1200 @ .75"	3.15 x 5/8	4.0	5.75	HX1	B43
T	1 HP	1200 @ 1.0"	3.15 x 5/8	1.5	5.75	HX1	B43
B	1 HP	1200 @ 1.0"	3.15 x 5/8	2.5	5.75	HX1	B43
T	1 HP	1400 @ .25"	3.15 x 5/8	2.0	7.75	HX1	B47
B	1 HP	1400 @ .25"	3.15 x 5/8	3.5	7.75	HX1	B46
T	1 HP	1400 @ .50"	3.15 x 5/8	2.5	6.75	HX1	B45
B	1 HP	1400 @ .50"	3.15 x 5/8	3.5	6.75	HX1	B44
T	1 HP	1400 @ .75"	3.15 x 5/8	2.5	5.75	HX1	B43
B	1 HP	1400 @ .75"	3.15 x 5/8	3.5	7.75	HX1	B43
T	1 HP	1400 @ 1.0"	3.15 x 5/8	4.0	4.75	HX1	B41
B	1 HP	1400 @ 1.0"	3.15 x 5/8	5.0	4.75	HX1	B41
T	1 HP	1600 @ .25"	3.15 x 5/8	2.5	6.75	HX1	B45
B	1 HP	1600 @ .25"	3.15 x 5/8	4.0	6.75	HX1	B44
T	1 HP	1600 @ .50"	3.15 x 5/8	1.5	6.75	HX1	B45
B	1 HP	1600 @ .50"	3.15 x 5/8	2.5	6.75	HX1	B45
T	1 HP	1600 @ .75"	3.15 x 5/8	2.0	5.75	HX1	B43
B	1 HP	1600 @ .75"	3.15 x 5/8	3.0	5.75	HX1	B43
T	1 HP	1600 @ 1.0"	3.15 x 5/8	3.5	4.75	HX1	B41
B	1 HP	1600 @ 1.0"	3.15 x 5/8	4.5	4.75	HX1	B41
T	1 HP	1800 @ .25"	3.15 x 5/8	3.5	5.75	HX1	B43
B	1 HP	1800 @ .25"	3.15 x 5/8	5.0	5.75	HX1	B42
T	1 HP	1800 @ .50"	3.15 x 5/8	3.0	5.75	HX1	B43
B	1 HP	1800 @ .50"	3.15 x 5/8	2.5	5.75	HX1	B43
T	1 HP	1800 @ .75"	3.15 x 5/8	1.5	5.75	HX1	B43
B	1 HP	1800 @ .75"	3.15 x 5/8	2.5	5.75	HX1	B43
T	1 HP	1800 @ 1.0"	3.15 x 5/8	3.0	4.75	HX1	B41
B	1 HP	1800 @ 1.0"	3.15 x 5/8	4.0	4.75	HX1	B41
T	2 HP	2000 @ .25"	3.15 x 7/8	2.5	5.75	HX1	B43
B	2 HP	2000 @ .25"	3.15 x 7/8	3.5	5.75	HX1	B43
T	2 HP	2000 @ .50"	3.15 x 7/8	1.5	5.75	HX1	B43
B	2HP	2000 @ .50"	3.15 x 7/8	2.5	5.75	HX1	B43
T	2 HP	2000 @ .75"	3.75 x 7/8	3.0	5.75	HX1	B43
B	2 HP	2000 @ .75"	3.75 x 7/8	4.5	5.75	HX1	B43
T	2 HP	2000 @ 1.0"	3.75 x 7/8	2.0	5.75	HX1	B44
B	2 HP	2000 @ 1.0"	3.75 x 7/8	3.0	5.75	HX1	B43
T	2 HP	2200 @ .25"	3.75 x 7/8	3.5	5.75	HX1	B43
B	2 HP	2200 @ .25"	3.75 x 7/8	5.0	5.75	HX1	B43

SHRV2500DD
AIR FLOW RATE (CFM)

NOTE: DRIVE SELECTIONS SHOWN ARE BASED ON 56 (56H) FRAME MOTORS
T= TOP FAN ASSY B= BOTTOM FAN ASSY.
ALL PULLEYS MUST BE CAST IRON

CONTINUED

FAN	MOTOR	CFM @ STATIC	MOTOR PULLEY (Inches)	TURNS OPEN	BLOWER PULLEY	BUSHING (Browning) (Inches)	BELT (Inches)
T	2 HP	2200 @ 50"	3.75 x 7/8	3.0	5.75	HX1	B43
B	2 HP	2200 @ 50"	3.75 x 7/8	4.0	5.75	HX1	B43
T	2 HP	2200 @ 75"	3.75 x 7/8	2.0	5.75	HX1	B44
B	2 HP	2200 @ 75"	3.75 x 7/8	3.5	5.75	HX1	B43
T	2 HP	2200 @ 1.0"	3.75 x 7/8	1.5	5.75	HX1	B44
B	2 HP	2200 @ 1.0"	3.75 x 7/8	2.5	5.75	HX1	B44
T	2 HP	2400 @ 25"	3.75 x 7/8	2.5	5.75	HX1	B44
B	2 HP	2400 @ 25"	3.75 x 7/8	4.0	5.75	HX1	B43
T	2 HP	2400 @ 50"	3.75 x 7/8	1.5	5.75	HX1	B44
B	2 HP	2400 @ 50"	3.75 x 7/8	3.0	5.75	HX1	B43
T	2 HP	2400 @ 75"	3.75 x 7/8	4.5	4.75	HX1	B41
B	2 HP	2400 @ 75"	3.75 x 7/8	5.5	4.75	HX1	B41
T	2 HP	2400 @ 1.0"	3.75 x 7/8	4.0	4.75	HX1	B42
B	2 HP	2500 @ 1.0"	3.75 x 7/8	5.0	4.75	HX1	B41
T	2 HP	2500 @ 25"	3.75 x 7/8	2.0	5.75	HX1	B44
B	2 HP	2500 @ 25"	3.75 x 7/8	3.0	5.75	HX1	B43
T	2 HP	2500 @ 50"	3.75 x 7/8	4.5	4.75	HX1	B41
B	2 HP	2500 @ 50"	3.75 x 7/8	5.5	4.75	HX1	B41
T	2 HP	2500 @ 75"	3.75 x 7/8	4.0	4.75	HX1	B42
B	2 HP	2500 @ 75"	3.75 x 7/8	5.0	4.75	HX1	B41
T	2 HP	2500 @ 1.0"	3.75 x 7/8	3.5	4.75	HX1	B42
B	2 HP	2500 @ 1.0"	3.75 x 7/8	4.5	4.75	HX1	B41
T	2 HP	2600 @ 25"	3.75 x 7/8	4.5	4.75	HX1	B41
B	2 HP	2600 @ 25"	3.75 x 7/8	6.0	4.75	HX1	B41
T	2 HP	2600 @ 50"	3.75 x 7/8	4.0	4.75	HX1	B42
B	2 HP	2600 @ 50"	3.75 x 7/8	5.0	4.75	HX1	B41
T	2 HP	2600 @ 75"	3.75 x 7/8	3.5	4.75	HX1	B42
B	2 HP	2600 @ 75"	3.75 x 7/8	4.5	4.75	HX1	B41
T	2 HP	2600 @ 1.0"	3.75 x 7/8	3.0	4.75	HX1	B42
B	2 HP	2600 @ 1.0"	3.75 x 7/8	4.0	4.75	HX1	B42

INTRODUCTION

The SHR2500 series of Heat Recovery Ventilators (HRV's) are designed for commercial and industrial applications to provide fresh air to a building and exhaust an equal amount of stale air. During the winter months, the incoming cold fresh air is warmed by utilizing the heat recovered from the stale air before it is exhausted to the outdoors. During the summer months, when the indoor air space is air conditioned, the HRV will help in cooling the incoming fresh air with the stale air that is being exhausted. Fresh air is distributed throughout the building by way of the existing duct system or a dedicated duct system.

SELECT THE CORRECT SIZE HRV

Commercial and Institutional Requirements

ASHRAE has produced the Ventilation Standard 62-1989 that is used to determine acceptable ventilation rates. This standard is referenced directly or used as Good Engineering Practice in most Code documents or design criteria.

Small Restaurants, Donut Shops & Fast Food Stores	
Seats	40
Employees	5
Total	45
ASHRAE Requirements	20 cfm (10 L/s) per person
Ventilation Required	45 X 20 = 900 cfm (450 L/s)
Bank	
Customers	25
Staff	9
Total	34
ASHRAE Requirements	20 cfm (10 L/s) per person
Ventilation Required	34 X 20 = 680 cfm (320 L/s)
Bar or Tavern	
Seats	50
Employees	7
Total	57
ASHRAE Requirements	30 cfm (15 L/s) per person
Ventilation Required	57 X30 = 1710 cfm (855 L/s)
Bingo Hall	
Customers	180
Staff	20
Total	200
ASHRAE Requirements	30 cfm (15 L/s) per person
Ventilation Required	200 X30 = 6000 cfm (3000 L/s)
Classrooms and School Portables	
Seats	29
Teacher	1
ASHRAE Requirements	15 cfm (7.5 L/s) per person
Ventilation Required	18 X 25 = 450 cfm (255 L/s)
Print Shop	
Square Footage of Shop	2000 sq. ft.
ASHRAE Requirements	0.5 cfm / sq. ft. (2.5 L/s – m 2)
Ventilation Required	2000 X 0.5 = 1000 cfm (500 L/s)
Beauty Salon	
Customers	12
Employees	6
Total	18
ASRAE Requirements	25 cfm (12.5 L/s) per person
Ventilation Required	18 X 25 = 450 cfm (255 L/s)
Swimming Pools	
1 cfm per sq. ft. of the water surface area or	
.5 cfm per sq. ft. of the water surface + deck area	
Hot Tubs	
7 – 10 cfm per sq. ft. of the water surface area	

MAKE – UP HEAT REQUIREMENTS @ 1200 CFM (566 L/s)				
Outdoor Temp		Nominal	Nominal	Nominal
°C	°F	kw req. for 20°C (68°F) Air Delivery	kw req. for 25°C (77°F) Air Delivery	kw req. for 30°C(86°F) Air Delivery
0	32	7	10	14
- 10	14	10	14	17
- 20	- 4	12	15	19
- 30	- 22	15	19	22
- 40	- 40	17	21	24

NOTE: ALWAYS REFER TO THE MOST RECENT VERSION OF ASHRAE VENTILATION STANDARD TO DETERMINE CFM REQUIREMENTS.

INSTALLATION INSTRUCTIONS

LOCATION

The HRV should be suspended from a supported ceiling ideally in a mechanical room proximate to an outside wall to establish outside venting and weather-hoods. This unit can only be mounted indoors and consideration should be give to the location of available power and water drainage for the unit’s condensation. When installing the unit, ensure that it is level and that adequate space is allowed around the unit for easy accessibility into the access doors for service and maintenance.

DUCT SYSTEM

The Duct System must be well designed to allow the HRV to operate at its’ maximum efficiency. It is very important the Duct System must be adequately sized and includes no sharp radius bends or tees which will significantly increase the pressure drop in the Duct System and reduce air flows.

Galvanized ducts must be sized for 1200 f.p.m. (6.09 m/s) maximum velocity; this is recommended to avoid excessive pressure drop and noise. Ducting should be as short as possible and use the minimum number of elbows and tees.

Connecting duct sections and shorter runs may be flexible ducting one size larger than the metal duct. The use of flexible duct connectors at the HRV will considerably reduce noise transmission. All duct joints must be secured with screws, rivets or duct sealant and sealed with aluminum tape.

DUCTING OUTSIDE OUTSIDE WEATHERHOODS

The Outside Weatherhoods required for operation of the SHRV2500 HRV are to be provided by the installing contractor. Weatherhoods must have built in bird screens to prevent birds and rodents from entering the premise through the ductwork. When designing and locating the fresh air intake, consideration should be given to the best place where the hoods will gather the freshest air, free from restriction.

We recommend:

- No less than 10 ft. (3 m) apart from each other.
- At least 18 in. (46 cm) above ground level or potential snow accumulation.
- Away from sources of contaminants, such as automobile exhaust fumes, gas meters, garbage containers, cooling towers, etc.
- Not exposed to prevailing winds, wherever reasonably possible.

The outside perimeter of the weatherhoods must be caulked to prevent leakage into the building. Roof vents must have adequate curb height for water protection and to be sealed to the ducting.

The design and size of the weatherhoods or louvers chosen by the installer, must allow for adequate free area. Water and snow penetration of the system is minimized when the airflow does not exceed 750 fpm (3.81 m/s) free area velocity.

WEATHERHOOD DUCTING

Galvanized metal ducting with sufficient cross section and with an integral single piece vapor barrier should be used to connect to the HRV to the weatherhoods. All ducting must meet ULC Class 1 Fire Rating and the minimum R-value of the insulation should be equal to 4 (RSI 0.75), or as stated in local codes.

All ducting must be well sealed to prevent air leaks and a sufficient bead of high quality caulking (preferably acoustical sealant) and taping with a high quality aluminum foil tape is recommended to seal the duct to both the HRV and the weatherhoods.

DUCTING WITHIN THE BUILDING

To reduce airflow restriction in the duct system, galvanized ducting should be used from the HRV to different areas within the building whenever possible. Also, to minimize airflow losses in the duct work system, all ducts should be as short as possible and incorporate as few elbows as possible. The use of 45° elbows is preferred to 90° elbows and Y tees instead of 90° tees is also recommended.

All duct joints must be fastened securely and wrapped with a quality duct tape, such as aluminum foil tape, to prevent leakage.

NOTE: See Installation Warning under the “Integrated HVAC System” section.

STALE AIR (RETURN) DUCT SYSTEM

The Stale Air (Return) Duct System is used to draw stale air from the points of the building where the worst air quality problems occur. Balancing dampers and, or, adjustable grilles are recommended on all return air lines which are used (during installation) to help balance the “draw” from different areas of the building. Note that the installation schematics show balancing dampers and, or, adjustable grilles on all return air lines coming back to the HRV. Please refer to figs. 1-3 to view the various installation system options.

A balancing damper is required prior to the HRV to balance the stale air exhausted with the fresh air supply entering the building.

Return air extraction points should be located at the opposite side of the room to the fresh air inlet. The inlets may be located in the ceiling or high on the walls and fitted with inlet grilles.

Many commercial activities produce air contaminants in the form of dusts, fumes, vapors and gases. Contaminates should be controlled at the source so that they are not dispersed through the building nor allowed to increase to toxic concentration levels. The HRV allows for economical operation of the HVAC system, while effectively removing contaminants from the space. In designing the exhaust portion of the system, the exhaust grilles are placed so as to remove the contaminants while not allowing them to enter the breathing zone of the occupants.

For contaminants that are lighter than air, grilles should be located high on the wall. If contaminants are heavier than air a lower placement of the grilles will

be required. Information on contaminants specific gravity and toxicity should be available from the chemical data sheets.

Dedicated Duct System

In this arrangement the HRV is installed with a dedicated duct system. All applicable rooms are exhausted and provided with fresh air supply as required. The main advantage of this type of installation is it provides the ability to balance the exhaust and supply air streams for each serviced room. The HRV system can also be operated independently of the forced air heating/cooling system.

Please refer to fig. below.

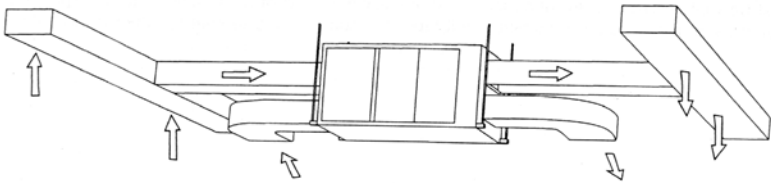

Indirect Duct System

This method of installation permits localized exhaust of indoor air and uses the existing forced air system to distribute fresh air. This system will therefore permit independent room balancing of exhaust stale air, however the distribution of fresh supply air cannot be balanced.

In this system, the fresh air supply can either be directly connected through a ceiling return air plenum into an air handler or directly into the return air duct into the air handler. Once through the air handler, the air then moves into the fresh air supply duct run.

Please see fig. below.

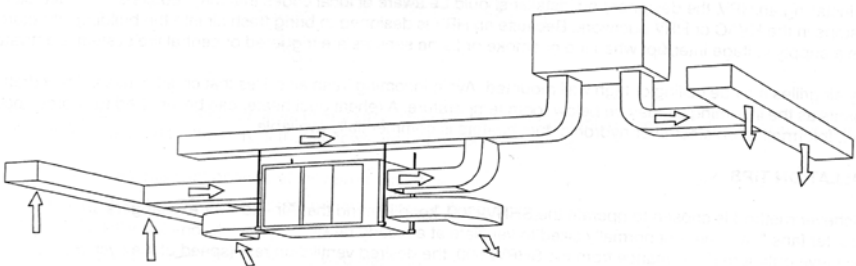

Simplified Duct System

This system is primarily used when it is impractical to install dedicated duct runs from the HRV to various rooms of the building. In this installation the warm air exhaust from the building to the HRV and fresh air supply from the HRV to the building are connected to the existing forced air duct system. This installation has the exhaust stale air may drawn directly from the return air duct.

When this system is used, the air handlers' blower will need to operate constantly when ventilation is required. The exhaust take-off connection must be at least 1 meter (3.28 ft) away from a directly connected HRV supply duct if both are connected to the same run.

Please see fig. below.

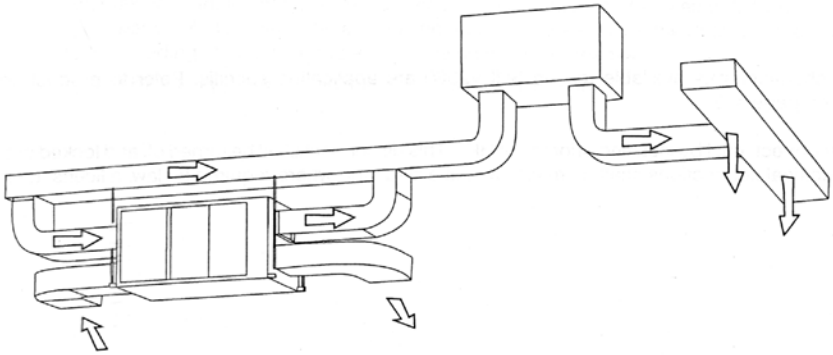

SUPPLY AIR DUCT SYSTEM

The fresh air supply ductwork from the HRV may be directly connected to the return air duct of the forced air system. When directly connected, it is recommended that the air handler blower be in constant operation to move the fresh air about the building (see warning under “The Integrated HVAC System”). Also, it is advisable to include a short length fabric flex duct or other non – metallic connector in this hard duct line in order to keep the HRV acoustically isolated and separately grounded (electrically) from the air handler. This will avoid a possible shock hazard to service people if a short to ground develops in one of the devices. It may be necessary to install a separate fresh air supply ductwork system if the heating is other than forced air.

When installing an HRV, the designer and installer should be aware of local codes that may require smoke detectors and / or firestops in the HVAC or HRV ductwork. Because an HRV is designed to bring fresh air into the building,

structures may require a supply voltage interrupt when fire or smoke or flame sensors are triggered or central fire system is activated.

Supply air grilles may be ceiling or high wall mounted. Avoid incoming fresh air grilles that could cause a direct draft on the occupants as the incoming air may be below room temperature. A reheat duct heater can be installed to improve occupant comfort. Information on electric or hydronic duct heaters is commercially available.

INSTALLATION TIPS

1. Whichever method is chosen to operate the SHR2500, keep in mind that Air – to – Air exchangers are not “booster fans”, and are not normally sized to ventilate at a steady rate. To achieve optimum performance from the SHR2500, the desired ventilation rate (speed of the system) should be reached before the contaminant has reached its’ maximum.
2. It is recommended that backdraft dampers be installed in the supply and exhaust ductwork to the outside, to prevent air from entering in through the HRV when the HRV is OFF. Failure to install backdraft dampers may result in damage to HVAC equipment and / or other building components.

INTEGRATED HVAC SYSTEM

Increasingly, the HRV has become an integral component of the commercial HVAC system. HRV’s are very versatile, being able to provide fresh air directly to the return air plenum of a rooftop heat / cool unit or into a ceiling return air plenum or directly into the ceiling space near the air handlers intake. Special care and attention should be given if connecting this unit to any air handler or other unit that may draw more than the SHR25500 is designed to accommodate.

Installations where it is satisfactory to provide general exhaust from the space, the air to be exhausted may be taken directly from the return air plenum to the HRV as it is drawn back to the air handler. Fresh air supplied by the HRV is then introduced directly into the return air plenum but at a location closer to the air handler. The air handler would have a constant running blower to effectively distribute the fresh air and remove the stale air. Balancing dampers would be located in both the HRV supply and exhaust ducts between the return air plenum and the HRV.

ELECTRICAL

The electrical characteristics available for the SHRV2500 are application specific. Refer to product specifications and nomenclature on page # 3.

An external disconnect must be installed prior to the HRV. This disconnect shall be turned off and locked out before servicing the unit. All electrical connections shall be made by a qualified, and where required by law, a licensed electrician.

PITOT TUBE AIR FLOW BALANCING

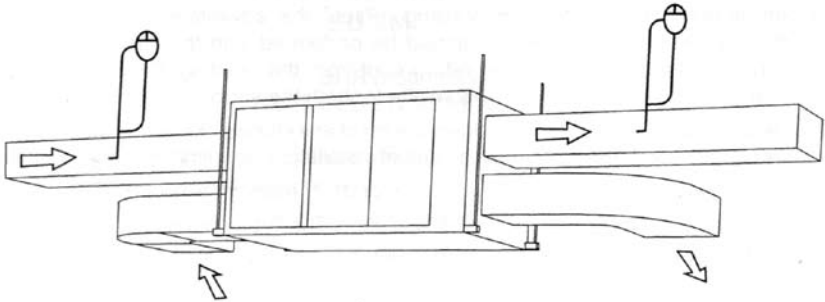

It is necessary to have balanced air flows in any HRV. The volume of air brought in from outside must be equal to the volume of air exhausted by the HRV. If the air flows are not properly balanced :

- The HRV may not operate at its' maximum efficiency.
- A negative or positive air pressure may occur in the building.
- The HRV may not defrost properly.
- Failure to balance the HRV may void warranty

Excessive positive pressure may drive moist indoor air into external walls of the building where it may condense (in cold weather) and degrade structural components. It may also cause key holes to freeze up.

Excessive negative pressure may have several undesirable effects. In some geographic locations, soil gases, such as methane and Radon gas may be drawn into the building through basement / ground contact areas. Excessive negative pressure may also cause back drafting of atmospherically vented combustion appliances.

**Read the Application WARNING on the Front Page of This Manual.
Prior to balancing, insure that :**

1. All sealing of the ductwork system has been completed.
2. All of the HRV's components are in place and function properly.
3. Balancing dampers are open.
4. HRV is on High Speed.
5. Air flows in branch lines to specific areas of the building should be adjusted first, prior to balancing the HRV. A smoke pencil used at the grilles is a good indicator of each branch line's relative air flow.
6. After taking readings of both the stale air to the HRV duct and fresh air to the building duct, the lower CFM (L/s) velocity reading should be left alone, while the duct with the higher reading should be dampered to match the lower reading.
7. Return HRV to appropriate fan speed for normal operation.

BALANCING PROCEDURE

The following is a method of field balancing an HRV using a Pitot Tube, advantageous in situations when air flow stations are not installed in the ductwork. This procedure should be performed with the HRV on High Speed. The first step is to identify the supply duct to the building and the return duct from the building. Choose the straightest section of duct between the HRV and any branches or take-offs. This will be for both the supply and return ducts. Drill a small hole in the duct (approx. 3/16") 3 feet downstream of any elbows or bends, and 1 foot upstream of any elbows or bends. These are recommended distances, but the actual installation may limit the amount of straight duct.

The Pitot Tube should be connected to a Magnahelic gauge or other manometer capable of reading from 0.0 – 1.0 in. (0-500 Pa) of water, preferably to 3 digits of resolution. The Tube coming out of the top of the Pitot is connected to the High Pressure side of the gauge. The Tube coming out of the side of the Pitot is connected to the Low Pressure or reference side of the gauge.

Insert the Pitot Tube into the duct, pointing the tip into the airflow.

More precise readings can be made by taking a number of readings through a cross section of the duct. The readings should be taken at the centers of equal areas in the duct.

This procedure is outlined in the instructions accompanying the Pitot Tube. This method is also described in the ASRAE Handbook of Fundamentals, chapter on measurements and instruments.

Determine which duct has the highest airflow (highest reading on the gauge). Then damper that airflow back to match the lower reading from the other duct. The airflows should now be balanced.

Actual airflow can be determined from the gauge reading. The value read on the gauge is called the velocity pressure. The Pitot Tube comes with a chart that will give the airflow velocity based on the velocity pressure indicated by the gauge. This velocity will be in either feet per minute or meters per second.

To determine the actual airflow, the velocity is multiplied by the cross sectional area of the duct being measured.

Example:

- This is an example for determining the airflow in a 6 “ duct
- The Pitot Tube reading was 0.025 “ W.C.
- From this chart, this is 640 f.p.m.
- The 6 “ duct has a cross sectional area
= $(3.14 \times \{ 6''/12 \}^2) / 4 = 0.2$ square ft.
- The airflow is then 640 ft / min. X 0.2 square ft. = 128 cfm

GENERAL OPERATING INSTRUCTIONS

SUMMERAIRE SHR2500 SERIES - HEAT RECOVERY VENTILATOR

ON / OFF SWITCH

The SHR2500 series HRV's are NOT supplied with an ON / OFF switch. The HRV's in this series are direct connected to their power source through a field supplied disconnect switch.

OPTIONAL REMOTE CONTROLS

Remote Dehumidistats, Timers, or switches can be easily installed to automatically turn fan onto high speed.

AUTOMATIC DAMPER STYLE DEFROST

The automatic damper defrost is factory pre – set and normally does not require adjustments. A temperature sensor, located in the fresh air supply stream, activates an electronic timer when the outdoor temperature drops to – 3°C (25°F). This timer controls the timing cycles of the defrost system. During the defrost cycle, the fresh air supply is shut off by the motorized multi blade damper assembly for approximately 5 – 7 minutes, ambient air from the building is designed to flow through the core assembly, melting any frost accumulations.

CORE AND FILTER CLEANING

The core assembly and filters are removed via the hinged access doors located on both sides of the HRV. By unscrewing the hex head screws that secure the access doors these cabinet doors can be opened, allowing the core assemblies and air filters to be removed from either or both sides of the HRV. Always use care when handling the core assemblies. At re assembly, ensure that cores are oriented properly, refer to THIS WAY UP and FILTERS THIS SIDE labels.

CLEANING

A visible inspection of the HRV should be made every 3 – 6 months. The core assembly can be easily removed and cleaned by immersing in soapy water and rinsing. The “ pleated “ type air filters can be removed and “ tapped” to remove excess dirt and dust and should be replaced annually, or as required. These steps must be carried out to prevent any build – up of dust dirt etc. Vacuuming the interior of the HRV may also be necessary annually. Also, check the outside fresh air intake hood and the stale air exhaust hood, and remove debris every 2 months. Do not let snow cover the outdoor weatherhoods.

CONDENSATE DRAINAGE

Periodically, inspect and clean the drip pan(s) and condensate hose. Check for any blockage which may disrupt normal drainage.

OPERATING INSTRUCTIONS SHRV2500 SERIES

SHRV2500 HRV's ARE NOT SUPPLIED WITH POWER DISCONNECTS.

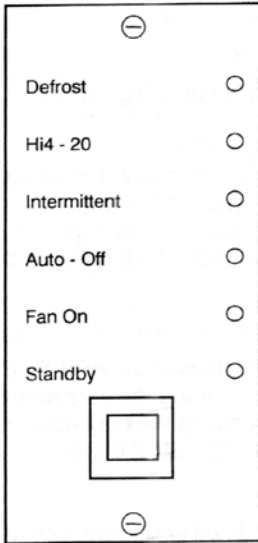

DEFROST
DISPLAY

ACTIVATED WHEN INCOMING AIR TEMPERATURE IS BELOW - 3 DEG C (25 o F). GREEN LED ILLUMINATES WHEN HRV IS IN DEFROST MODE.

Defrost



Hi4 - 20



Hi4 - 20

HRV OPERATES HRV AT HI SPEED FOR 20 MIN. THEN SWITCHES TO FAN OFF.

Intermittent



INTERMITTENT

40 MINUTES OF FAN OFF FOLLOWED BY 20 MINUTES OF FAN ON. THIS CYCLE REPEATS.

Auto - Off



AUTO-OFF

FAN OFF UNLESS ACTIVATED BY A CONTROL i.e. EXTERNAL DEHUMIDISTAT OR CRANK TIMER.

Fan On



HIGH SPEED

HRV OPERATES ON HIGH SPEED CONTINUOUSLY.

Standby



STANDBY

FAN OFF, PERIPHERALS DO NOT RESPOND. CONTROL POWERED, COLD SUPPLY DAMPER CLOSED.

Note: The default position of the main control board is FAN ON any time that power is turned off to the HRV.

MAINTENANCE

As with any mechanical system, a dedicated maintenance program will prolong the life of the equipment, and maintain its' optimum performance. We recommend at least two (2) full inspections and cleanings per year under normal operating conditions, and more, if circumstances warrant it.

Service Should Include:

- Cleaning of screens protecting the outside hoods
- Cleaning the core – core assembly is made up of 3 cores. To access the core, remove service panels and slide core half way out. Wash core(s) protruding from the cabinet with water and / or a mild cleaning solution. Push core through to the other side of the cabinet and repeat the procedure to clean the other side of the core. In many cases, only a vacuuming of the core surface is required.
- Always ensure that cores are installed correctly. Refer to labels referring to “Core This Way Up” and “Air Filters This Side”.
- Inspect filters and replace as necessary.
- Wipe down drain pans and inside of the cabinet using a mild disinfectant.
- Ensure condensate drain has free flow of moisture.
- Inspect blowers and electrical disconnect panel.
- Confirm operation.

MOTORS

Apply 4 – 5 drops of oil to the ports at each end of the motor every 12 months is required. We strongly recommend that the motor (s) should be oiled once every year in order to extend its' life. USE S.A.E. 20W NON – DETERGENT OIL. Do not “over oil”, as this may damage the motor. Depending on the HRV specifications, the motors may have sealed bearings that do not require oiling. An inspection of the motors will identify if oiling is required.

WIRING DIAGRAM SHRV2500

High Voltage
 Low Voltage

Note: L1 and L2 voltages are determined by application. Refer to Unit Specification Label for motor voltages. Power disconnect switch to be field supplied and must meet local codes and standards.

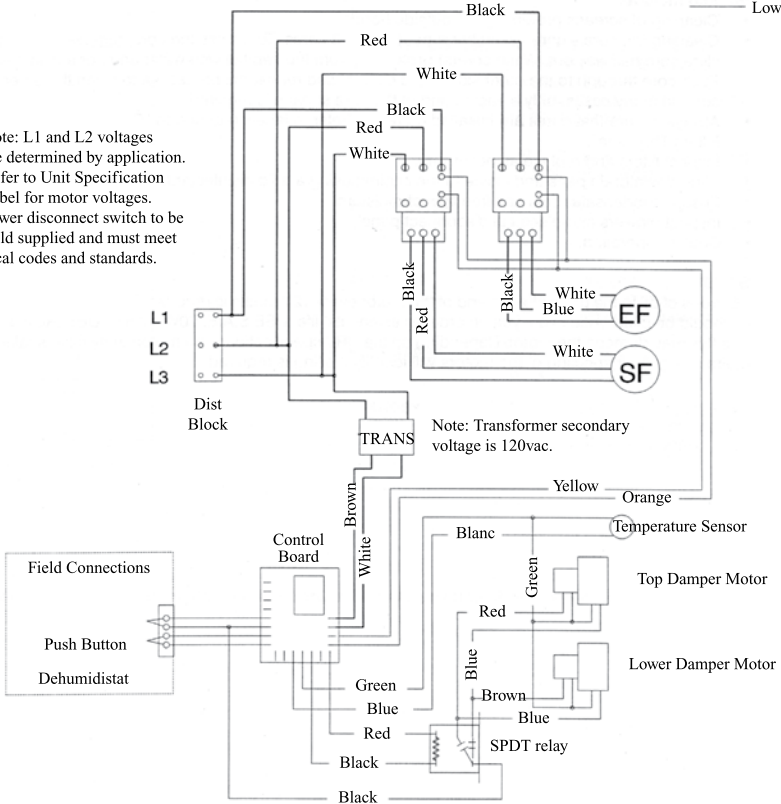

SHRV2500 SERVICEABLE PARTS

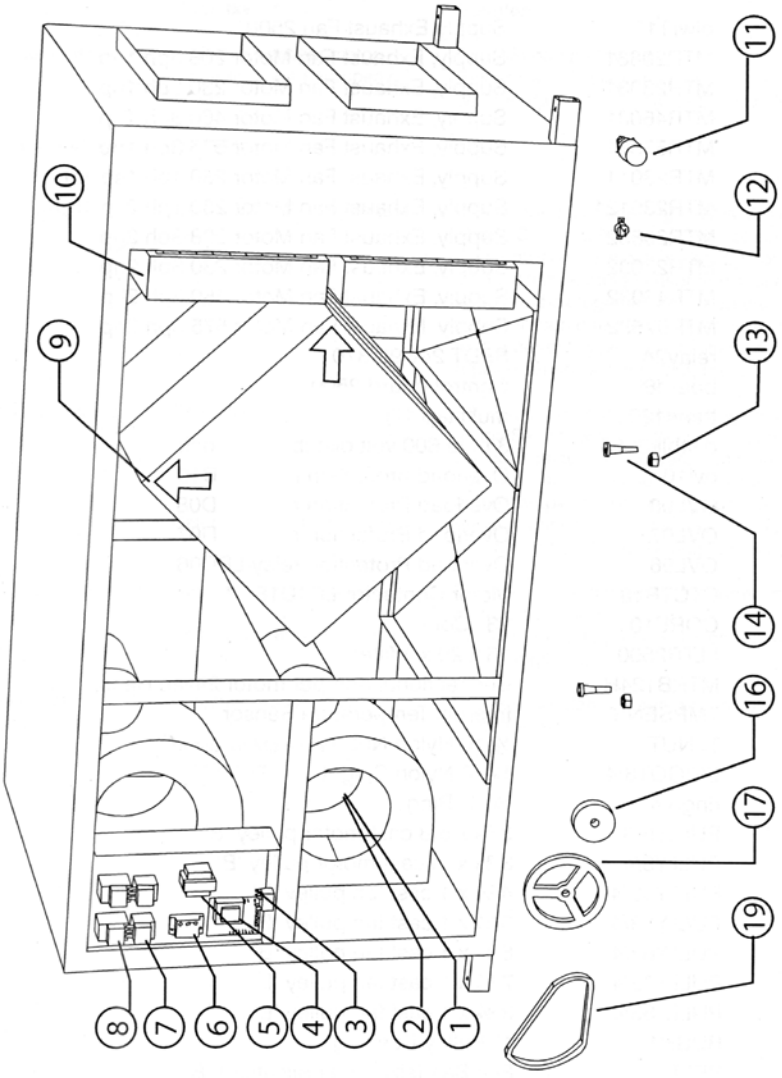

Parts List

Item No.	Part Number	Description	Qty per unit
1	blwrT12	Supply Exhaust Fan 2500	2
2	MTR20831	Supply, Exhaust Fan Motor 208 3ph 1hp	2
	MTR23031	Supply, Exhaust Fan Motor 230 3ph 1hp	2
	MTR46031	Supply, Exhaust Fan Motor 460 3ph 1hp	2
	MTR57531	Supply, Exhaust Fan Motor 575 3ph 1hp	2
	MTR23011	Supply, Exhaust Fan Motor 230 1ph 1sp 1hp	2
	MTR230121	Supply, Exhaust Fan Motor 230 1ph 2sp 1hp	2
	MTR20832	Supply, Exhaust Fan Motor 208 3ph 2hp	2
	MTR23032	Supply, Exhaust Fan Motor 230 3ph 2hp	2
	MTR46032	Supply, Exhaust Fan Motor 460 3ph 2hp	2
	MTR57532	Supply, Exhaust Fan Motor 575 3ph 2hp	2
3	relay24	SPDT 24v 90-370	1
4	board6t	Control board 2500	1
5	trans120	multi tap 120vac. Sec.	1
6	distblk3600	3 pole 600 volt distribution block	1
7	ovl10	Overload protection relay LRD10	2
	OVL08	Overload Protection relay LRD08	2
	OVL07	Overload Protection relay LRD07	2
	OVL06	Overload Protection relay LRD06	2
8	CTCTR18	Motor Contactor LC1D18G7	2
9	CORE10	23" Core	3
10	FLTR2500	16 x 20 x 4 filter	2
	FLTR2500B	16 x 25 x 4 filter	2
11	MTRB124H	Bi-directional damper motor 24vac Hans.	2
12	TMPSENS	Internal Temperature Sensor	1
13	34 NUT	34-10 Nylon Nut	2
14	SPIGOT3/4	34-10 Nylon Spigot	2
15	ring3/4	3/4" O Ring	2
16	PULLY5/8	3 3/4 x 5/8 cast motor pulley 'B'	2
	PULLY3/4	3 3/4 x 3/4 cast motor pulley 'B'	2
17	PULLY43/4	4 3/4 x 1 cast fan pulley 'B'	2
	PULLY53/4	5 3/4 x 1 cast fan pulley 'B'	2
	PULLY63/4	6 3/4 x 1 cast fan pulley 'B'	2
	PULLY73/4	7 3/4 x 1 cast fan pulley 'B'	2
	PULLY83/4	8 3/4 x 1 cast fan pulley 'B'	2
18	BUSH1	1" Pulley Bushing	2
19	BELT	Fan Belt (size on application) 'B'	2

SHRV2500DD
Trouble Shooting Guide

Symptom	Possible Cause	Solution
Cold supply damper closed during fan on	Defective damper motor.	Replace damper motor
	Damper motor improperly wired	Refer to wiring diagram, reverse wires to damper motor at SPDT relay in control box.
Defrost damper open fan on.	See above.	
Defrost cycle inactive.	Cold supply air temperature too warm	If air temperature entering HRV is above -3 deg C then defrost cycle will not activate. If air temperature is below -3 C Disconnect leads at temperature sensor and splice leads going to control box together. Power up unit, HRV will cycle through one run cycle (approx. 25 minutes) then a defrost cycle should initiate. If it does, replace sensor, if it does not, replace control.
Both dampers should do not change	Defective control relay.	SPDT damper motor control relay respond as the Select switch on the Main Control Board is cycled. If relay does not respond then replace. Note that capacitors must be positioned across the leads to the damper motor windings on the relay.
	Defective Main Control Board	Replace control board if no power output to relay coil. Should be 24vac. During fan on cycle.
One fan motor fails to start	Defective motor contactor.	Replace. Refer to parts list for correct type for motor application.
	Defective overload protector.	Replace. Refer to parts list for correct type for motor application.
LED Control panel does not illuminate at power up.	Defective Transformer	Check secondary voltage. Should be 120vac If not, replace.
	Defective Main control transformer	Replace.

SUMMERAIRE

Commercial Heat Recovery Ventilator Limited Warranty

Summerraire Mfg. warrants this product to the original owner, should it prove to be defective by reason of faulty manufacturing material or workmanship within two (2) years of the purchase date. Extended warranty is offered for the “Core” as outlined below.

Core(s)

Summerraire Mfg. warrants the “Core” of the commercial Heat Recovery Ventilator to the original purchaser for a period of fifteen (15) years if the “Core” has become defective by reason of defective manufacturing material and or/faulty workmanship.

The General Provisions outlined below form an integral part of this warranty.

General Provisions

This warranty covers normal use and does not cover defects caused by: modification, improper installation or misapplication, abuse to, or operation of the product in a manner contrary to the instructions included with the unit at the time of shipment, or failure to perform maintenance as detailed in the aforementioned instructions.

Summerraire Mfg. will provide a replacement HRV unit or component as prescribed in the foregoing section, F.O.B Peterborough, Ontario, Canada. This warranty does not include freight, labor, including diagnostic labor, or sales tax that might be incurred by the purchaser if parts require replacement. Replacement units and/or components are warranted for the remainder of the original warranty period.

Summerraire Mfg. is not responsible for providing an authorized service center near the purchaser or in the general area.

Under no circumstances shall Summerraire Mfg. be liable to the purchaser or any other person(s) for any consequential damages, whether arising out of breach or warranty, breach of contract, negligence or otherwise in the use of the ventilation system.

This warranty expressly supercedes all other warranties and obligations of Summerraire Mfg. whether expressed or implied. No person has authority to alter or

modify the terms of this warranty in any manner

Keep your warranty at work for you. Please complete and mail your Warranty Registration Card to Summeraire Mfg., 2040 Fisher Drive, Peterborough, Ontario, Canada, K9J 6X6 to register this warranty.

Notes:



Built Better to Last Longer

SUMMERAIRE MFG.
PETERBOROUGH, ONTARIO
CANADA
K9J 7B1

X-2500DD-INSUSMAN-EN-REV4